

# Bench Grinder Safety

Make sure the manufacturer's recommended speed, as posted on the wheel, is compatible with your grinder

**Always protect your eyes--**  
wear only an eye or face shield bearing the logo **Z-87**

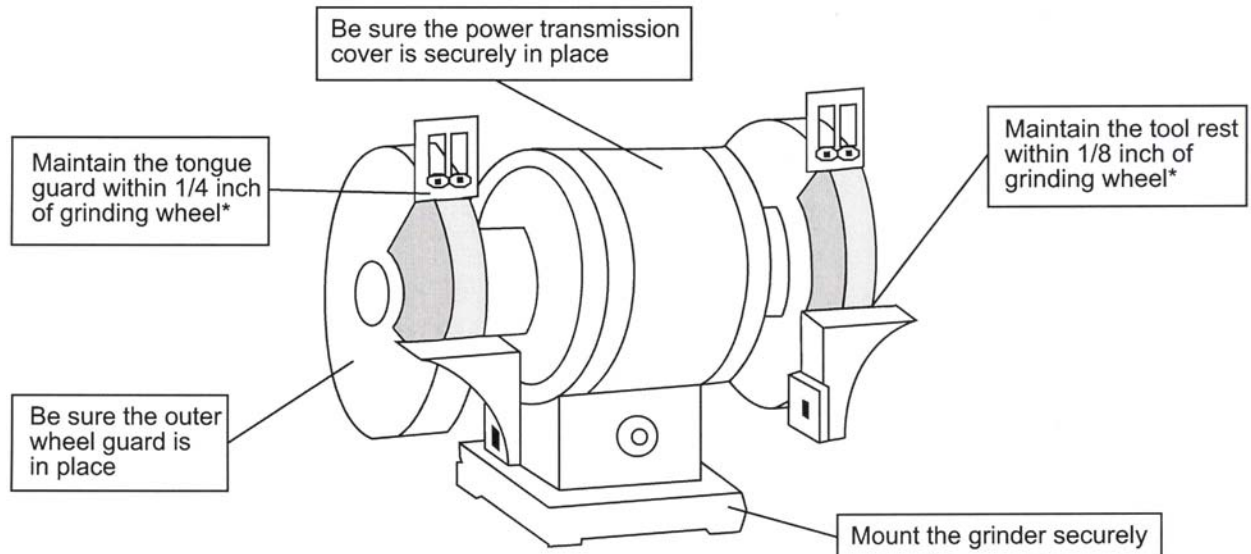

\* As the wheel wears down, readjust the tool rest and tongue guard. When you can no longer adjust them, replace the wheel.

**Important:** When installing a new wheel, closely follow the manufacturer's instructions. An improperly installed wheel can break (right) and cause injury.

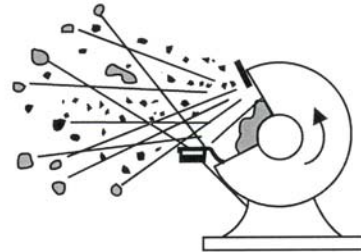

- ❖ Do Not Grind On Side Of Wheel Unless Designed For Side Grinding
- ❖ Do Not Gouge Wheel By Grinding In One Spot
- ❖ Do Not Grind Aluminum, Brass, Copper Or Wood
- ❖ Check Max Rotational Speed & Ring Test New Wheel Before Installing.
  - Ring Test:
    - Tap Wheel 1-2" From Periphery 45° Each Side Of Vertical With Non-Metallic Screwdriver Handle "Dead" Sound Indicates Crack

For Additional Information, See 29 CFR1910.215.